

Apollo Flow Measurement Ltd
WFC/5 Flowmeter Manual
Issue 3
November 1999

Installation & Operation of the WFC5 Frequency to Current Converter

Note

Read this manual prior to installation

CONTENTS

- 1 Introduction
- 2 Installation
 - 2.1 Mounting
 - 2.2 Electrical Connections
 - 2.3 Signal Connections
 - 2.4 Installation Diagram
- 3 Signal Outputs
- 4 Calibration
- 5 Fault Finding Guide
- 6 Technical Specification

1 INTRODUCTION

The WFC/5 instrument provides analogue outputs of 0-20mA or 4-20mA, and 0-1mA proportional to the frequency of the output signal from a flowmeter. It comprises a single PCB housed in an insulated, chemically resistant, IP65 enclosure.

The WFC/5 is designed for back-of-panel or field mounting via integral case holes.

The two current outputs are:-

- (i) Either 0-20mA or 4-20mA
- (ii) 0-1mA

In addition there is an unscaled TTL pulse output.
The outputs are electrically isolated from the inputs.

This instrument conforms to the EMC Directive of the Council of European Communities 89/336/EEC, provided the wiring instructions in section 2 are followed.



2 INSTALLATION

2.1 Mounting

The enclosure can be wall mounted via fixing screws inserted through the holes in the base corners. The holes are accessible with the instrument cover removed.

2.2 Electrical Connections

The instrument is mains powered, the voltage is link selectable to either 120V or 240V nominal (+10%, -20%). Maximum power requirement is 3VA. A mains transformer provides isolation between the mains and the electronic circuitry. The use of a mains filter will give added protection from mains borne transients.

All signal cables should be screened to reduce the pick-up of electrical noise.

The screens should be connected to ground at one end only. If a bonded earth bus bar is available, for example, carrying intrinsically safe zener barriers, then this should be used otherwise the screens should be connected to the 0V rail (Terminal 4) of the instrument.

To comply with Directive 89/336/EEC of the Council of European Community, this wiring practice is mandatory. It is also good practice to separate power cables from signal cables.

Components on the PCB are sensitive to static. Suitable anti-static precautions must be taken when the cover is removed.

Changing Mains Voltage

Warning Disconnect Power Supply Before Dismantling.

1. Remove the cover after disconnecting the power supply.
2. The operating voltage is set by means of soldered links on the PCB as shown below:-

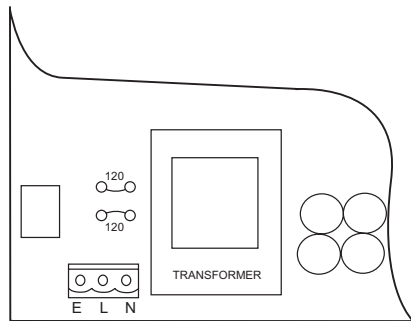

a. Fit links as shown above for operation at 110/120V A.C.

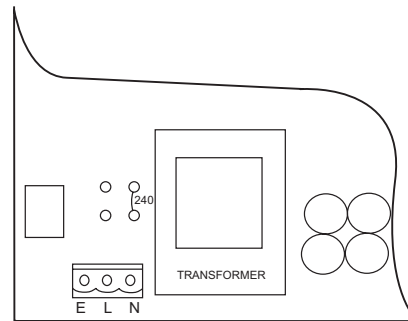

b. Fit links as shown above for operation at 220/240V A.C.

Care must be taken to avoid the use of excessive heat when soldering.

2.3 Signal Connections

<u>Signal Type</u>	<u>Typically From</u>	<u>Connections</u>	<u>Links on PCB</u>
Voltage Pulse (square wave)	PPW Amplifier TTL	+ve to 3 -ve to 4	ef
Voltage Pulse (sine wave)	Turbine Meter	10 & 11 no polarity	efg
Switch (contact closure)	Reed Switch	4 & 6 no polarity	ef
Open Collector	Magnetic Meters	+ve to 6 -ve to 4	ef
Current Pulse	P/5 Amplifier	+ve to 2 -ve to 1	ef
Current Pulse	Namur Sensor	+ve to 2 -ve to 1	d

2.4 Installation

Power Input

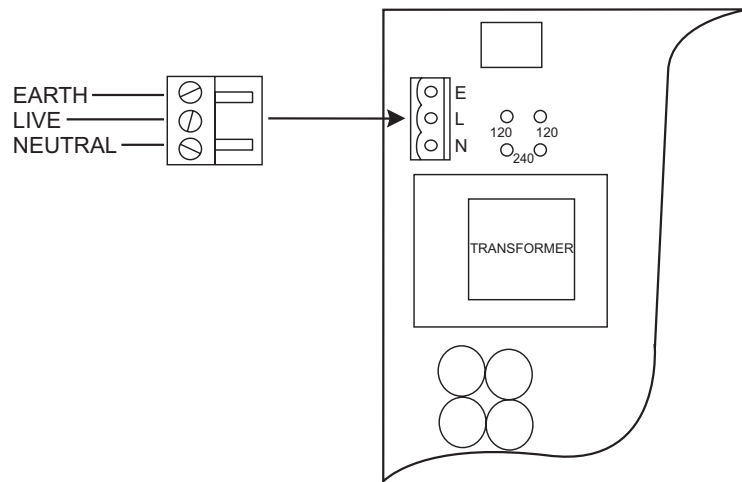

Signal In & Outputs

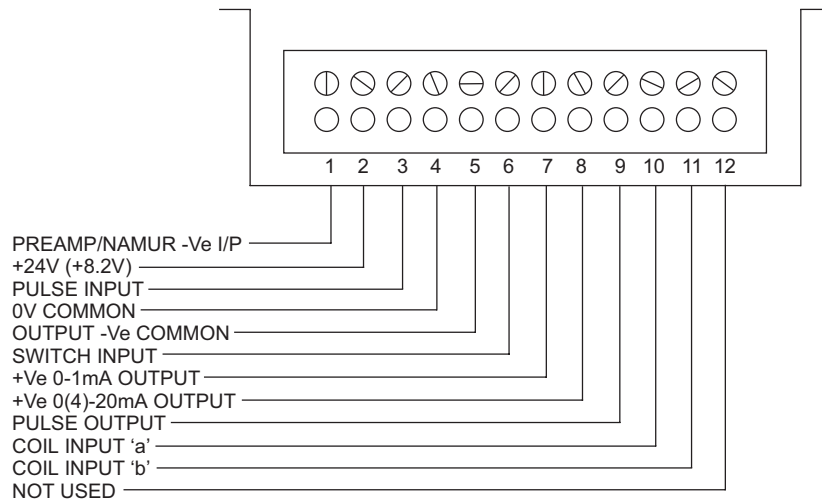

3 SIGNAL OUTPUTS

(a) 0-20mA or 4-20mA

This current output which is proportional to flowrate, is available between 8 (positive) and 5 (negative) and will drive into 800 Ω . It is fully floating with respect to mains and signal inputs but shares a common negative with the 0-1mA output below. For 4mA standing current fit link h.

(b) 0-1mA

This current output, which is also proportional to flowrate, is available between 7 (positive) and 5 (negative) and will drive into 16k Ω . It is fully floating with respect to mains and signal inputs but shares a common negative with the 0 - 20 / 4-20mA output above.

Note:

Both outputs are short circuit proof due to current limiting circuitry.

4 CALIBRATION

If purchased with a flowmeter the WFC/5 will be factory set.

WARNING: MAINS TRACKS ON PCB.

1. Remove the front cover of the instrument, observing static precautions.
2. Calibration of the instrument is set using four switches and two potentiometers.

Selection of the input/output options is by soldered link.

Identification and location of the switches/links etc. is shown below.

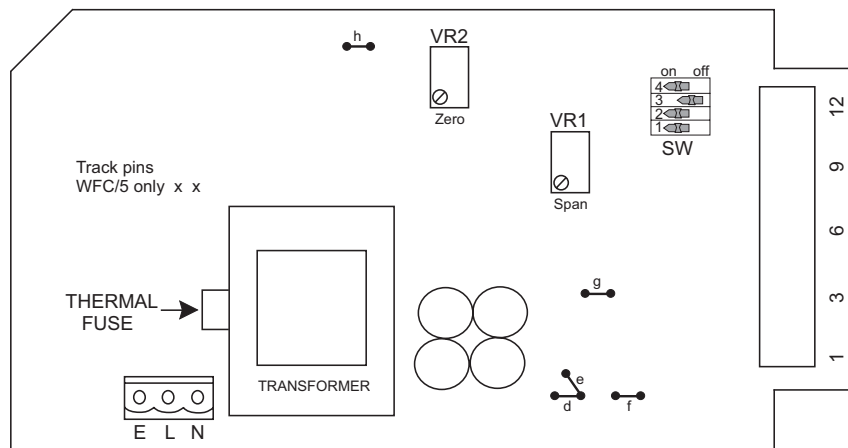

3. Link 'h' is fitted where a standing current, normally 4mA is required.

Link 'g' is fitted when the inductive coil input is to be used.

Link 'd' is fitted when the NAMUR input is to be used (terminal two at 8.2 Volt).

Link 'e' is fitted as standard when the NAMUR input is not required.

4. There are two parts to the calibration:-

- (a) Setting the standing current of 4mA for zero input. This is set using VR2 with link 'h' fitted.
- (b) Setting the 20mA at maximum input frequency. Course adjustment is achieved with switches 1 to 4 and fine adjustment with VR1.

Connect a signal generator to the appropriate input by reference to section 2.3.

Connect a millampere meter to the output, terminal 5 (common) and terminal 8 (positive).

Decide the input frequency that you wish to be equal to the maximum output of 20mA. (For a flowmeter this will normally be the "meter factor" (pulses/unit volume) multiplied by the maximum flowrate (unit volume/unit time) converted to pulses/second).

EXAMPLE From the calibration certificate of the flowmeter :

meter factor = 20.3 pulses/litre

max. flow rate = 100 litres/min

maximum frequency = 20.3 x 100 pulses/min
= 2030 pulses/min
= 33.8 Hz (pulses/sec)

Refer to the table overleaf and set switches SW1, 2, 3 and 4 according to the maximum frequency calculated.

MAX FREQUENCY					SW1	SW2	SW3	SW4
Between	9	and	10.6	HZ	0	0	0	1
"	10.2	"	12.4	"	1	0	0	1
"	12.0	"	15.0	"	0	1	0	1
"	14.6	"	18.8	"	1	1	0	1
"	12.2	"	23.0	"	0	0	1	1
"	22.4	"	34.0	"	1	0	1	1
"	32.6	"	66.0	"	0	1	1	1
"	58	"	650	"	1	1	1	1
"	360	"	430	"	0	0	0	0
"	400	"	500	"	1	0	0	0
"	450	"	600	"	0	1	0	0
"	590	"	760	"	1	1	0	0
"	700	"	950	"	0	0	1	0
"	900	"	1400	"	1	0	1	0
"	1300	"	2680	"	0	1	1	0
"	2400	"	5000+	"	1	1	1	0

NOTE: 0 = OFF
1 = ON

If your maximum frequency falls within more than one setting choose the one nearest the bottom of the table.

EXAMPLE Setting SW1, 2, 3 and 4 from the previous example:

Maximum frequency = 33.8 Hz

Settings possible : between 22.4 and 34.0 and
between 32.6 and 66.0

Choosing the second of these gives :

SW1 - OFF / SW2 - ON / SW3 - ON / SW4 - ON

1. Where 4mA standing current is required:-

With link 'h' fitted and frequency generator 'off' adjust VR2 to set the output to 4.00mA.

2. Where zero output is required:-

Remove link 'h' if fitted.

3. To set the output span, inject a signal at $\frac{1}{2}$ of maximum required frequency and adjust VR1, setting the output to 12.00 mA. Increase the frequency to the maximum and check that the output is 20.00 mA \pm 0.03. The injection of lower frequencies will provide an output that is proportional to the input frequency. The 0-1mA output on terminals 5 (common) and 7 (positive) is automatically set by the above procedures.

4. Remove calibration leads and refit instrument cover.

5 FAULT FINDING GUIDE

If the instrument fails to function follow these instructions.

Select the symptom from the following table:-

0-1mA O/P	Not Working	Working	Not Working
0(4) - 20mA O/P	Not Working	Not Working	Working
Refer to Instruction	1	2	3

1. a) Check the power supply.
- b) Check voltage between terminals 2 & 4 and 5 & 4.

If no voltage on either, check external circuits for short circuit, correct supply voltage and links before replacing thermal fuse or PCB.

- c) Check transmitter is working.
 - d) Check that a signal is reaching the instrument.
 - e) Check all connections for broken wires, loose terminal screws or trapped cable insulation.
2. a) Check that the loop impedance of the 0(4) - 20mA output circuit is not greater than 800R.
 - b) Check external wiring.
 - c) If external wiring is correct disconnect cables from output and connect a milliamperemeter directly across terminals 5 (-) and 8 (+). Replace PCB if no output is obtained.
3. a) Check external wiring.
 - b) If wiring is correct disconnect external circuit wiring and connect a milliamperemeter directly across terminals 5 (-) and 7 (+). Replace PCB if no output is obtained.

6 TECHNICAL SPECIFICATION

Construction: Polycarbonate case with chloroprene gasket

IP Rating: IP65
Standard: DIN 43700
Mounting: Integral holes

Connections: Internal PCB terminal block via IP65
compression cable glands

Power Requirement:
Mains: 120/240V ac RMS (+10% - 20%)
45/60 HZ 3 VA max.

Aux Power Outputs: +24V dc nom unregulated 60mA
Or: +8V2 dc 12mA

Input Signals:

a)	Pick-off coil: (link selectable)	Frequency range Min sine wave	3HZ - 3KHZ 5mV RMS @ 100HZ 15mV RMS @ 1HZ 45mV RMS @ 3KHZ
		Maximum voltage Hysteresis Input Resistance Input Capacitance	5V RMS 4mV 20K 22nF
b)	Pre-amplifier: * (link selectable)	Frequency range Input resistance Max input Sensitivity: low level current high level current hysteresis	DC - 3KHZ 27R 0.25W 8mA 11mA 1mA
c)	Switch closure: *	Frequency range Energising current Energising voltage Hysteresis	DC - 1KHZ 10mA 5V via 4K7 1V/1mA
d)	Pulse: *	Frequency range Input resistance Logic high voltage Logic low voltage Maximum input voltage Hysteresis	0.1 - 3KHZ 100K 2V5 1V 40V 600mV
e)	Namur: (link selectable) *	Frequency range Supply voltage Logic high Logic low Input resistance Input max.	DC - 3KHZ 8V2 max. 2.2mA 1mA 120R 1% 0.25W

* If any of these inputs is held high it will inhibit all other inputs, hence it can be used as a gate to control an input signal to one of the other inputs.

Temperature Operating Range: -20°C to +45°C

Outputs:

- (i) 0-20 or 4-20mA into 800
- (ii) 0-1mA into 16k

Response time : Approx. 400 m.sec to 60%

Linearity : 0.15% over 25:1 frequency range

Temp coefficient : 0.015%/°C at output

Connections:

PCB mounted screw terminals

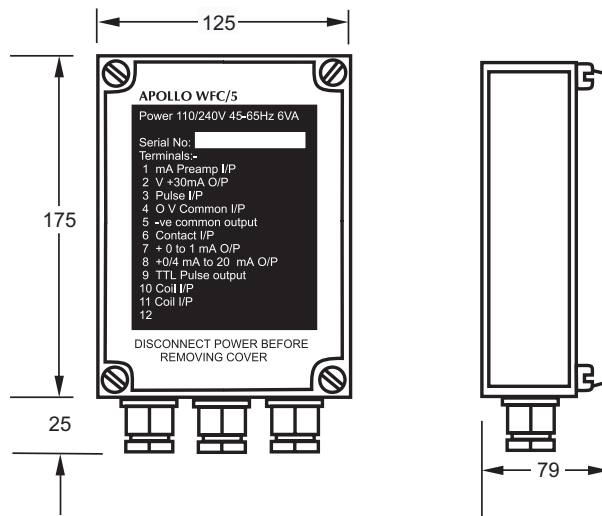

Dimensions in mm